



# DI965E14

## 90CM COOKER WITH ELECTRIC OVEN



### Features

- 5 burner gas hob with triple wok burner and automatic electronic ignition
- Cast iron trivets
- 116 litre oven capacity
- Digital clock for accurate time control
- High capacity cooling fan
- 6 Oven functions - fan forced, convection, bake, grill, fan grill, fan assist and light
- Warming/storage compartment below oven
- Flame failure safety devices to all burners
- Titanium easy clean enamel
- Click & slide inner door glass

### Accessories Included

- 2 wire racks, grill tray with rack
- LPG Conversion kit
- Full metal door handle & double glass door
- Removable oven side racks
- Height adjustable stainless steel legs
- Made in Italy

### OVEN FUNCTIONS

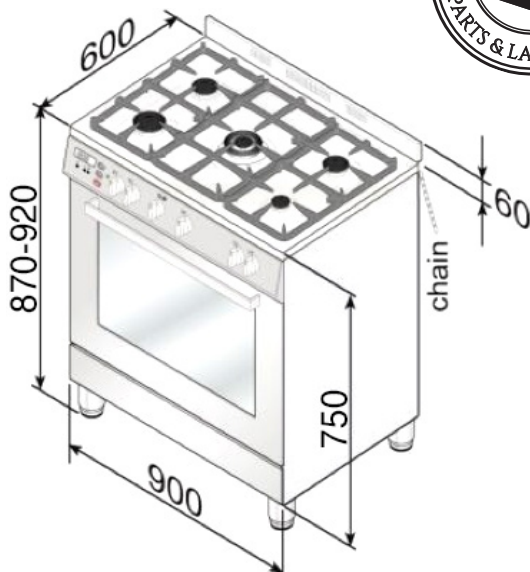

### Power Specifications

- Wok burner 14.5 Mj/h (11.5)
- Large burner 11.5 Mj/h (10.0)
- 2x Medium burner 7.0 Mj/h (6.0)
- Small burner 4.0 Mj/h (3.5)
- Total gas consumption 44.0 Mj/h (37.0)

Allow 5mm clearance to cupboards

Suitable for flexible hose gas connection

Maximum electrical consumption 2515W

15 amp electrical connection

### Product Dimensions

900mmW x 870/920mmH x 600mmD

Oven internal dim = 670Wx370Hx410D

### Installation Information

Optimum ventilation will ensure cabinets and oven components to remain cooler and prevent possible overheating of the oven.

Please note:

Dimensions and specifications are a guide only refer to the instruction manual for full instructions. Every effort has been made to ensure this information is correct. However, due to product improvement Daniela Appliances reserves the right to make changes to products without prior notice.